



DAVIES, CRAIG PTY.
LTD.
A.B.N. 71 004 918 825 A.C.N. 004 918 825
MELBOURNE AUSTRALIA

77 Taras Avenue
P.O. Box 363
Altona North, Vic 3025 Australia
Phone: +61(0)3 9369 1234
Fax: +61(0)3 9369 3456
E-mail: dcfans@daviescraig.com.au
Web: www.daviescraig.com.au



Quality
Endorsed
Company
ISO 9001
Lic No 4528
Standards
Australia

DCSL8, DCSL9, DCSL10, DCSL12, DCSL14, DCSL14HP, DCSL16 FAN KIT INSTALLATION INSTRUCTIONS

BEFORE BEGINNING INSTALLATION, PLEASE READ ALL THESE INSTRUCTIONS FULLY. FAILURE TO COMPLY WITH ALL THE INSTRUCTIONS MAY INVALIDATE THE MANUFACTURER'S WARRANTY.

A. PREAMBLE

Congratulations on purchasing a Davies, Craig fan kit for your vehicle. This fan unit is suitable for both condenser (air-conditioning) and radiator (engine) cooling and your retailer will have advised you on the most suitable model for your application. If in doubt or if you have any further queries please contact Davies, Craig direct on (03) 9369 1234.

B. KIT REQUIREMENTS:

This kit includes all parts necessary for condenser cooling. **If you wish to cool the vehicle radiator you should purchase a Davies, Craig "Thermal Switch Kit" Part # 0401 from your retailer. If you wish to cool both the radiator and condenser you should purchase a "Thermal Switch & Relay Kit" Part # 0404 which contains a Thermal Switch and an extra relay and wiring loom.**

C. FAN ORIENTATION

ALL FAN KITS ARE REVERSIBLE AND MAY BE MOUNTED EITHER **UPSTREAM** (IN FRONT OF RADIATOR/CONDENSOR) OR **DOWNSTREAM** (ON THE ENGINE SIDE OF THE RADIATOR / CONDENSOR).

WHEN THIS FAN LEFT THE FACTORY IT WAS ASSEMBLED TO BE MOUNTED **UPSTREAM**

IF THERE IS INSUFFICIENT SPACE IN FRONT OF THE RADIATOR / CONDENSER, THE FAN MAY BE MOUNTED DOWNSTREAM, PROVIDED FOUR STEPS ARE TAKEN **BEFORE** MOUNTING.

FOR **DOWNSTREAM** MOUNTING

(I): REMOVE THE CLIP OR HEX NUT, WHICH KEEPS THE FAN BLADE IN POSITION.

(II) REMOVE THE FAN BLADE FROM THE MOTOR SHAFT, TURN IT OVER AND REPLACE. IN EVERY CASE THE INSTRUCTION, PRINTED

ON THE BLADE, 'THIS SIDE MUST FACE FRONT OF VEHICLE' MUST BE FOLLOWED.

(III) RESECURE THE FAN BLADE

(IV) BEFORE MOUNTING THE FAN TO THE FACE OF THE RADIATOR / CONDENSER, NOTE THE DIRECTION OF THE ARROW ON THE FAN BLADE AND WHEN WIRING, ENSURE THE FAN ROTATES IN THE DIRECTION OF THE ARROW IN ALL CASES.

BEST PERFORMANCE WILL BE ACHIEVED BY MOUNTING CONDENSER FAN(S) TO THE CONDENSER AND RADIATOR FAN(S) TO THE RADIATOR.

If you are having your fan fitted by a professional, please ask that the instructions be read in full even if there has been some experience in Davies, Craig Thematic Fan installation.

Vehicles used for towing caravans and large trailers may need to retain the standard belt-driven fan, at least in summer, with the electric fans fitted in the upstream position. Air-conditioned cars should be fitted with a condenser fan such as the DCSL9 or DCSL10 if one is not already fitted. The DCSL12 and DCSL14 are suitable for cooling condensers on large sedans and wagons and the DCSL14HP or DCSL16 is suitable for condenser cooling on large commercial vehicles.

D. INSTALLATION OF FANS

There are four stages involved in the installation of your Davies, Craig Fan(s).

- (i). MOUNTING OF FAN ASSEMBLY.
- (ii). INSTALLATION OF THERMAL SWITCH.
(Radiator Cooling)
- (iii). WIRING.
- (iv). SETTING THE THERMAL SWITCH.
(Radiator Cooling)

(i). MOUNTING OF FAN ASSEMBLY

CONDENSER COOLING ONLY

1. If you have purchased the fan to cool the condenser, it should be mounted **upstream**. NOW GO TO PARAGRAPH 4 (Radiator Cooling).

RADIATOR COOLING

2. Remove the original belt driven fan and shroud. After removing fan from the pulley, replace the bolts in the water pump hub. You may need washers (not provided) to replace the thickness of the belt driven fan.

3. Decide which face of the radiator you wish to mount the fan(s). If you are fitting two fans it may be necessary to fit the larger of the two upstream and the smaller downstream, with as little overlap as possible.

4. Please pay particular attention to the markings on the fan hub regarding the direction the fan should face. This instruction must be followed, whether there is an upstream or downstream mounting.

5. Please note the direction of the rotation arrow on the hub/blade as once the fan is installed the arrow may not be visible.

6. Position the unit directly on the face of the radiator/condenser. Take care that the fan and shroud does not foul any struts, engine pulleys, bonnet latches etc., including when the bonnet is closed.

7. For DCSL 8,9,10,12, check that the wires exit the motor downwards (i.e.: at 6 o'clock), so that any condensation formed in the motor will drain.

8. Depending on the room available and the presence of a condenser, you may prefer at this point to remove the radiator from the vehicle to ease the fitting procedure.

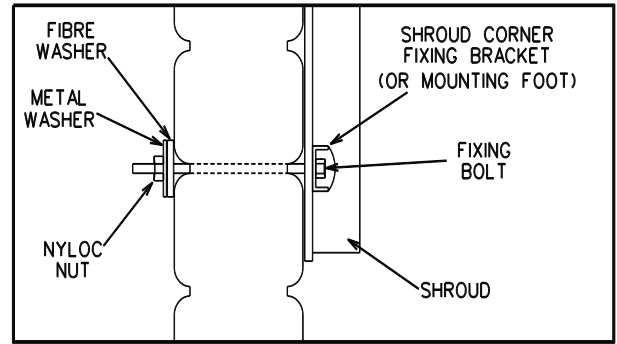

9. Separate the condenser/radiator fins at the four points where the mounting bolts are to be passed through the radiator between the tubes. Use a pencil or "phillips head" screw-driver to separate the fins, being careful not to damage the tubes.

10. Fix the fans(s) to the radiator/condenser using the long bolts and nuts provided, together with the fibre and steel washers as per above diagram.

NOTE: Long bolts are supplied to accommodate thick cores. Ensure that the protruding bolts do not foul any other radiator cores or engine parts. Trim with bolt cutters if necessary.

11. Before wiring, spin the fan by hand to ensure free and unobstructed rotation.

(ii) INSTALLATION OF THERMAL SWITCH – SOLD SEPARATELY

(RADIATOR COOLING)

ii a) Mechanical Thermal Switch (Part No.0401) Installation

1. When the engine is cold, remove the top radiator hose at the radiator end.

2. Mount the thermal switch to the bracket with the two small screws provided. Mount the bracket beside the radiator with the two large self-tappers so that the stainless steel bulb will reach the top radiator ferrule (pipe) and so that the adjustment

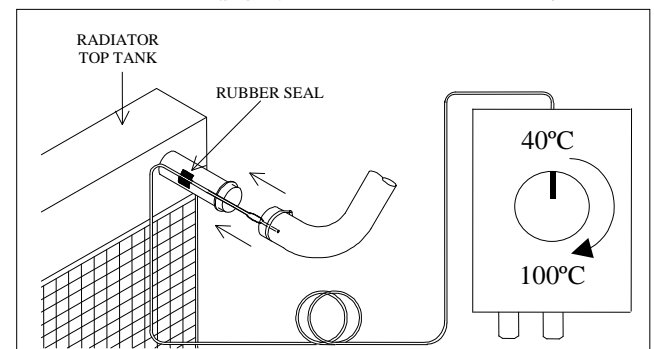

shaft is available for adjustment.

3. Lay the rubber seal along the radiator ferrule and place a section of the stainless steel capillary of the thermal switch down the groove in the rubber

seal. Keep the capillary loosely coiled and avoid sharp bends. Do not pass the bulb at the end of the capillary further down the hose than necessary as the frequent movement of the engine in relation to the radiator may cause fatigue. You may choose to use insulation tape to hold the seal in place while the hose is refitted. Replace radiator hose, position hose clamp across centre of seal with the clamp screw on the opposite side to the capillary. A good silastic type sealant may be used if there is a persistent leak.

ii b) Electronics Thermal Switch (Part No.0402)

Installation

1. Mount the control box next to the radiator using the self tapping screws provided. It must be mounted so as to allow access to the temperature adjusting screw and must be kept away from high heat sources, such as exhaust manifolds and pipes.

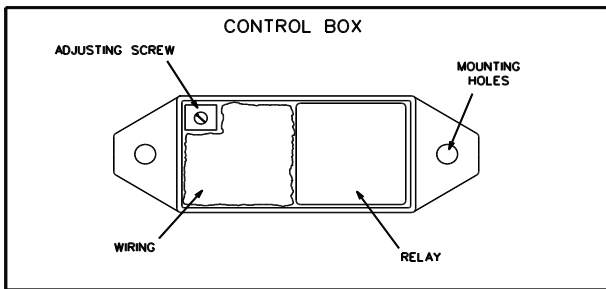

2. Select the temperature sensor mounting location before installing the fan. Sensor installation requires access to both sides of the radiator. Remove the radiator and/or condenser, if necessary, to allow access to both sides.
3. For best temperature sensing, install the sensor near the coolant inlet in the finned section in the top of the radiator. Select a location that will not interfere with the fan. The sensor may not extend completely through the core of the radiator. This will not affect operation.
DO NOT INSTALL THE SENSOR IN THE RADIATOR HOSE, SERIOUS DAMAGE WILL RESULT!

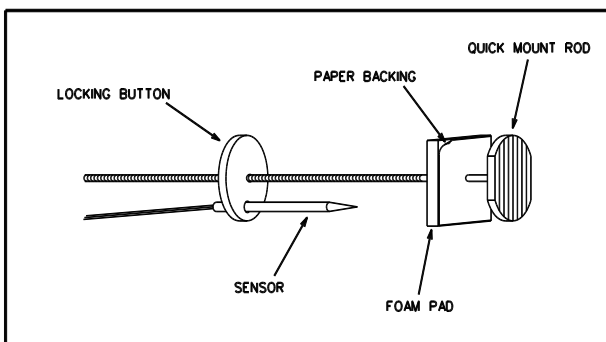

4. Remove Quick Mount rod, button and foam pad from parts bag. Remove paper backing from foam pad. Slide the pad onto the Quick Mount rod, adhesive side first.
5. Separate the fins in area of sensor installation using the Quick Mount rod or similar so as to not damage the tubes. Insert the Quick Mount rod through the separated fins. Push button and sensor onto Quick Mount, align and insert into the separated fins, pull tight and cut off excess rod.

(iii). WIRING

(CONDENSER AND/OR RADIATOR COOLING)

The kit(s) you have purchased contain relay and wiring looms to make fitting easy. Choose one of the six wiring diagrams shown (on the attached sheet) that matches your application.

1. Using the self-tapper screw provided, mount the relay(s) (with wiring loom attached), to a metal surface between the fan(s) and the battery. Ensure that the short black lead with the ring terminal is attached **BETWEEN** the screw head and the relay to complete the earth circuit.
2. Using the ring terminal provided, connect the red lead from the loom to power direct from the battery +ve.

NOTE: Do not make permanent connections to the fan motors until you have checked the direction of rotation of the fan blades.

3. Temporarily connect leads from the motor to the black and blue leads of the harness in accordance with the chart.
4. Follow the colour coded wiring diagram using the connectors provided. When connected to the ignition circuit, the fans should be wired to operate only when ignition is on.

WARNING Do not use the vehicle's engine management system or wiring connected to the management system as an ignition source as it may cause failure of the management system and/or the electrical system. The ignition source must be a steady positive supply of 12 or 24V DC.

5. The thermal switch must be wired as indicated in the diagram for your application.

FITTING FOR CONDENSER AND/OR RADIATOR COOLING IS NOW COMPLETE.

(iv). SETTING THE THERMAL SWITCH (RADIATOR COOLING)

Install control knob on to shaft.

Turn on ignition and rotate adjustment knob anti-clockwise until it stops. The fan(s) will run if the engine temperature is above 40°C - If the fan(s) do not cut-in, partially warm the engine to bring the engine temperature in to the range of the Thermal Switch.

If the fan turns in the direction of the arrow on the fanblade, make the motor connections permanent. If not, swap the motor leads and make permanent.

To confirm airflow direction, place a piece of newspaper (or similar) on the fan shroud. Air must flow through the grill, through the radiator and onto the engine.

Ensure that all electrical connections are permanent and properly insulated, and that all wiring is fitted so as to avoid sharp edges and hot parts of the engine.

1. Turn thermal switch adjustment fully clockwise. The fan(s) will turn off.
2. Run engine until the engine temperature is about half-way between the "normal highway operating temperature" and "too hot". This will indicate a coolant temperature between 5 to 10°C higher than normal.
3. Immediately, turn adjustment very slowly anti-clockwise, just until the fan(s) switches on and no more.
4. Allow the fan to run long enough to reduce the temperature by approximately the thickness of the temperature gauge needle before it turns itself off.

On a cool day it should run between 30 and 60 seconds at a time. On a hot day it may be somewhat longer.

If the fans run for more than a few minutes at a time, turn the adjustment clockwise slightly to increase the cut-in temperature. The fans must be set to cut in above normal operating temperature, otherwise they will run more frequently and for longer periods than necessary, and you may not achieve all the benefits of electric cooling.

NOTE: Remember that coolant under pressure in a radiator boils at about 118 degrees C.

If in doubt about any aspect of these instructions consult your retailer or Davies, Craig P/L direct on (03) 93691234 or e-mail dcfans@daviescraig.com.

IMPORTANT NOTES

Four Wheel Drives - monitor engine temperature closely when using off-road at low forward speeds in hot weather. If you wish, supplement cooling with the Davies, Craig EWP – Electric Water Pump Part No. 8005 or 8025 as an auxiliary pump.

Towing of heavy boats and caravans can cause overheating. Thermatic fans can help to solve this, particularly if mounted in front of the radiator and, if necessary, used in conjunction with the standard belt driven fan, or an EWP.

Air-conditioned vehicles normally require a condenser fan in conjunction with the standard (not over-sized) belt driven fan.

It is possible to eliminate the belt driven fan all together by using a combination of Thermatic Fans suitable to your vehicle, as set out on the 'Model Selection Guide', with an air-conditioner condenser fan. This will give you all the benefits of electric cooling.

If overheating persists there may not be enough coolant flow. The Davies Craig EWP (Electric Water Pump) Part No. 8005 or 8025, used as an extra pump, will solve the problem. More details are on our website. www.daviescraig.com.au.

Vehicles for which Thermatic Fans will not be suitable:

1. Trucks above approximately two tonnes tare capacity, particularly with van bodies, unless used as auxiliary cooling.
2. Forward-control vehicles where the radiator is set back from the grille. The radiator may need a scoop across the bottom to improve ram air at high cruising speeds in hot weather.
3. Air-cooled and rear-engine vehicles.

WARRANTY

1. The benefits covered by this warranty extend to all the components in this kit and are in addition to all other rights and remedies in respect of the kit which the consumer has under the Trade Practices Act and similar State and Territory laws.
2. The benefits of this warranty are available to the original purchaser and also to any party who may acquire the kit or the car to which it is fitted during the period of warranty.
3. Any faulty components returned to Davies, Craig Pty Ltd at its address and within 2 years or 1500 hours (whichever is the lesser) of the purchase date, with information as to the date and place of purchase, will be replaced provided that the defect is not due to collision, mis-use, including total immersion in water, abuse, neglect or failure to follow installation instructions. Proof of date and place of purchase must be provided.
4. This warranty will also apply to components replaced, for a period of two years or 1500 hours (whichever is the lesser) from the date of original purchase and under the same conditions.
5. Replacement components are available from Davies, Craig Pty Ltd. at the above address and from some retail outlets. Note that repair facilities for component parts are not available.
6. This kit is for the purpose of replacing the original belt-driven radiator fan, or for additional or condenser cooling (depending on model) when installed according to the instructions provided.
7. Guidance by the supplier as to which model may be suitable for a particular car will be given in good faith. But due to varying factors, the purchaser should check space available and the air-flow required for the car, rather than relying on the suppliers judgement.
8. WARNING – it is essential that the installation instructions are strictly followed.
9. Labour and consequential costs are excluded from this warranty.

TROUBLE SHOOTING

The following notes are designed to help you overcome the most common problems experienced by customers with Thermatic fans:

1. FAN RUNS NORMALLY BUT ENGINE OVERHEATS
CHECK:
 - a. Correct model is fitted
 - b. Thermal Switch is set correctly
 - c. Fan blade facing the right way and rotating in direction of the arrows and in accordance with chart.
 - d. Fan/s connected to full 12V power source.
 - e. Fan too far from face of radiator
 - f. Other cooling system problems
2. FAN RUNS WHEN CAR TRAVELLING AT MEDIUM TO HIGH SPEEDS
CHECK:
 - a. Adjustment of thermal switch
 - b. Is the vehicle towing?
 - c. Other cooling system faults
3. FAN DOES NOT RUN OR RUNS SLOWLY
CHECK:
 - a. Fuses
 - b. Adjustment of thermal switch –set too high!
 - c. Wiring integrity
 - d. Connect motor(s) directly to battery then trace wiring towards switch if motor(s) runs.
 - e. Check earth connections.

WARRANTY REGISTRATION:

To ensure warranty protection, complete and return within 10 days to:

Davies, Craig Pty. Ltd., P.O. Box 363, Altona North, VIC 3025 Australia

Name: Purchase Date:.....

Address: State: Postcode:



Purchased From: Product: Model No.(s):.....

Fitted to Vehicle Make: Model:..... Year:

P/No:0950

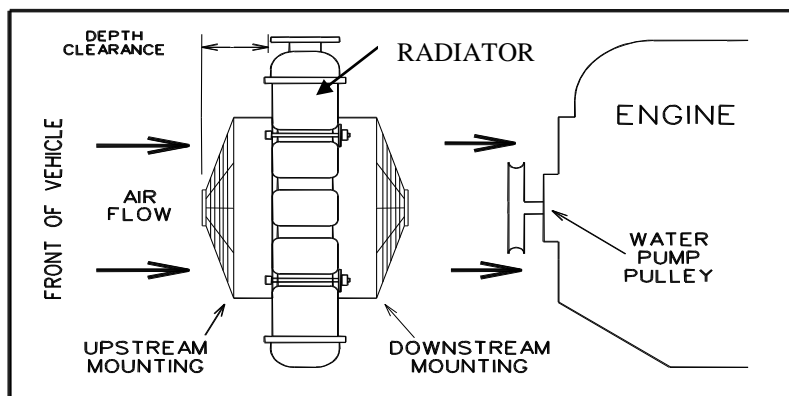
FAN ROTATION AND POLARITY

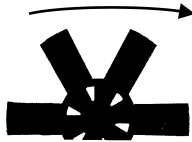
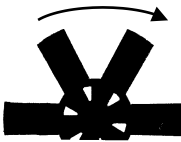

Davies, Craig Fan models		UPSTREAM	DOWNSTREAM
DCSL-8 DCSL-9 DCSL-10 DCSL-12 DCSL-16 DCSL-14HP	MOTOR-EARTH WIRE	BLUE or RED	BLACK
	FAN ROTATION		
DCSL-14	MOTOR-EARTH WIRE & FAN ROTATION	BLACK 	BLUE or RED 

NOTE: Rotation as viewed from front of vehicle must be clockwise in all cases, except DCSL-14 which rotates anti-clockwise.

Colour of motor earth lead depends on fan location upstream or downstream.

The two terminals on the thermal switch are equivalent. It does not matter which goes to ignition and which goes to the relay. When the switch closes it just connects the two terminals.

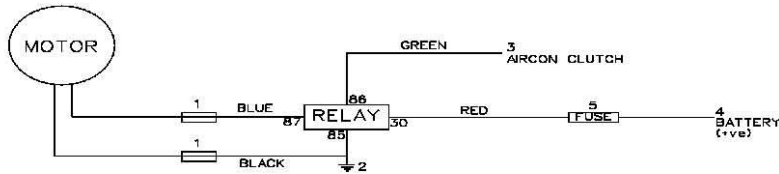

1 ONE FAN, CONDENSER ONLY

- 1 BLUE CONNECTOR (FROM FAN KIT)
 - 2 SELF TAPPER (FROM FAN KIT)
 - 3 SCOTCHLOCK (FROM FAN KIT)
 - 4 RING TERMINAL (FROM FAN KIT)
 - 5 FUSE HOLDER & FUSE (FROM FAN KIT LOOM)
- PURCHASE: 1 FAN KIT**

WARNING: ENSURE IGNITION SOURCE IS NOT CONNECTED TO THE ENGINE MANAGEMENT SYSTEM

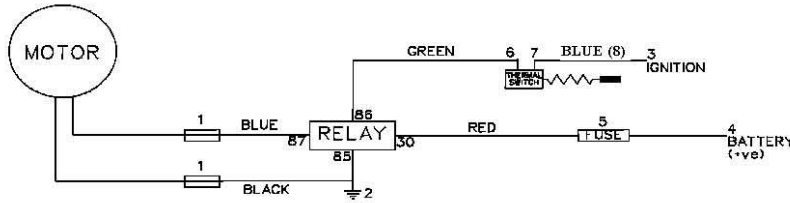

2 ONE FAN, THERMATIC ONLY

- 1 BLUE CONNECTOR (FROM FAN KIT)
 - 2 SELF TAPPER (FROM FAN KIT)
 - 3 SCOTCHLOCK (FROM FAN KIT)
 - 4 RING TERMINAL (FROM FAN KIT)
 - 5 FUSE HOLDER & FUSE (FROM FAN KIT LOOM)
 - 6 FEMALE SPADE BLUE (FROM THERMAL SWITCH KIT)
 - 7 FEMALE SPADE BLUE (FROM THERMAL SWITCH KIT)
 - 8 COILED BLUE WIRE (FROM THERMAL SWITCH KIT)
- PURCHASE: 1 FAN KIT, 1 THERMAL SWITCH KIT P/NO: 0401**

WARNING: ENSURE IGNITION SOURCE IS NOT CONNECTED TO THE ENGINE MANAGEMENT SYSTEM

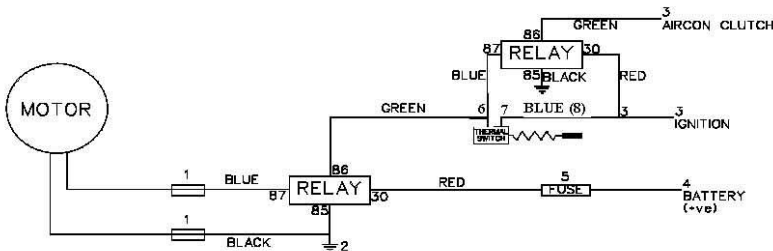

3 ONE FAN, CONDENSER AND / OR THERMATIC

- 1 BLUE CONNECTOR (FROM FAN KIT)
 - 2 SELF TAPPER (FROM FAN & THERMAL SWITCH KIT)
 - 3 SCOTCHLOCK (FROM FAN & THERMAL SWITCH KIT)
 - 4 RING TERMINAL (FROM FAN KIT)
 - 5 FUSE HOLDER & FUSE (FROM FAN KIT LOOM)
 - 6 FEMALE SPADE BLUE (FROM THERMAL SWITCH KIT)
 - 7 FEMALE SPADE BLUE (FROM THERMAL SWITCH KIT)
 - 8 COILED BLUE WIRE (FROM THERMAL SWITCH KIT)
- PURCHASE: 1 FAN KIT, 1 THERMAL SWITCH & RELAY KIT P/NO: 0404**

WARNING: ENSURE IGNITION SOURCE IS NOT CONNECTED TO THE ENGINE MANAGEMENT SYSTEM

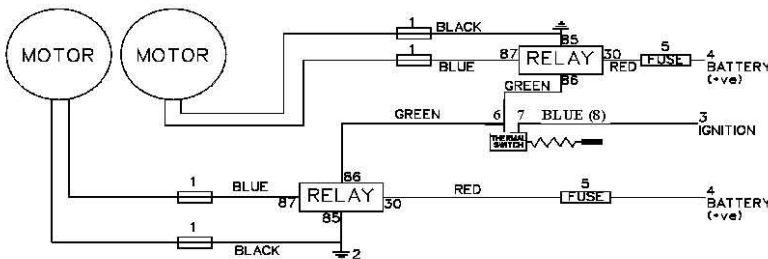

4 TWIN FANS, THERMATIC ONLY

- 1 BLUE CONNECTOR (FROM FAN KITS)
 - 2 SELF TAPPER (FROM FAN KITS)
 - 3 SCOTCHLOCK (FROM FAN KITS)
 - 4 RING TERMINAL (FROM FAN KITS)
 - 5 FUSE HOLDER & FUSE (FROM FAN KITS)
 - 6 FEMALE SPADE BLUE (FROM THERMAL SWITCH KIT)
 - 7 FEMALE SPADE BLUE (FROM THERMAL SWITCH KIT)
 - 8 COILED BLUE WIRE (FROM THERMAL SWITCH KIT)
- PURCHASE: 1 FAN KIT, 1 THERMAL SWITCH KIT P/NO: 0401**

WARNING: ENSURE IGNITION SOURCE IS NOT CONNECTED TO THE ENGINE MANAGEMENT SYSTEM

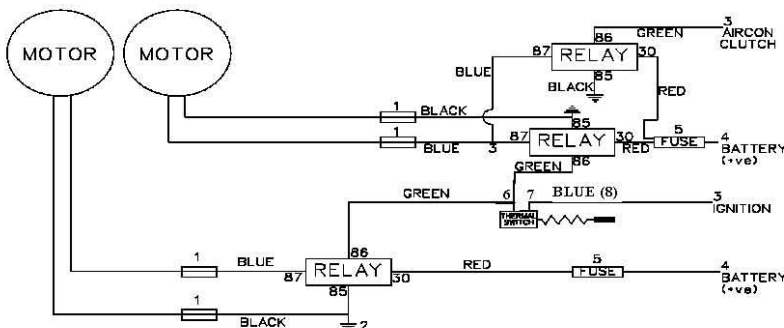

5 TWIN FAN, THERMATIC SINGLE FAN CONDENSER

- 1 BLUE CONNECTOR (FROM FAN KITS)
 - 2 SELF TAPPER (FROM FAN & THERMAL SWITCH KIT)
 - 3 SCOTCHLOCK (FROM FAN KITS)
 - 4 RING TERMINAL (FROM FAN KITS)
 - 5 FUSE HOLDER & FUSE (FROM FAN KITS)
 - 6 FEMALE SPADE BLUE (FROM THERMAL SWITCH KIT)
 - 7 FEMALE SPADE BLUE (FROM THERMAL SWITCH KIT)
 - 8 COILED BLUE WIRE (FROM THERMAL SWITCH KIT)
- PURCHASE: 2 FAN KITS, 1 THERMAL SWITCH & RELAY KIT P/NO: 0404**

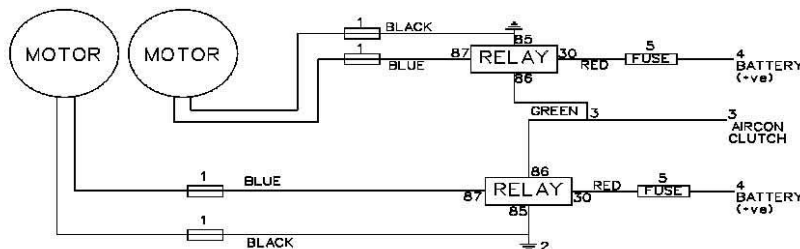

6 TWIN FANS, CONDENSER ONLY

- 1 BLUE CONNECTOR (FROM FAN KIT)
 - 2 SELF TAPPER (FROM FAN KITS)
 - 3 SCOTCHLOCK (FROM FAN KITS)
 - 4 RING TERMINAL (FROM FAN KITS)
 - 5 FUSE HOLDER & FUSE (FROM FAN KITS)
- PURCHASE: 2 FAN KITS**

EWP[®] ELECTRIC WATER PUMP

The world's most advanced total engine cooling management



- ✓ *more power*
- ✓ *more cooling*
- ✓ *increase fuel efficiency*
- ✓ *world-leading Australian technology*
- ✓ *extend engine life*
- ✓ *universal fit*



Part #8030

The EWP[®] 115 Electric Water Pump and EWP[®] Fan Digital Controller

The EWP[®] 115 is the latest in Davies, Craig's range of simple, DIY electric water pumps designed to replace your existing belt-driven water pump.

Lighter and more powerful, the EWP[®]115 (115 litres per minute) pump is suitable for small, medium, large, high-performance and 4WD vehicles. It's a performance accessory that improves engine cooling control and capacity whilst giving you more power and torque and improved fuel economy.

Mechanical belt-driven water pumps run directly off the motor and sap engine power ... the EWP[®]115 is hard-wired into your electrical system, by-passing the engine and releasing up to an additional 15kw (20hp).

Combined with the EWP[®] Fan Digital Controller, the pump continues to run after you've switched off, eliminating "heat soak" and extending engine life.

Davies, Craig's revolutionary, Australian-designed EWP[®] pumps are made from anti-corrosive, lightweight, glass-filled nylon. Their universal fit allows for easy mounting into the bottom radiator hose.

Our kits come with easy-to-understand DIY instructions and everything you need for easy installation, including different couplings to fit every hose size and all necessary electrical wiring.

The EWP[®]115 and EWP[®] Fan Digital Controller Combination Pack is the most economical way to increase horsepower and save on fuel consumption whilst caring for your engine.



The EWP[®] 115 & EWP[®] Fan Digital Controller will suit almost every vehicle

For assistance or advice, please contact Davies, Craig or visit www.daviescraig.com.au