



**DAVIES, CRAIG**  
 PROPRIETARY LIMITED  
 A.B.N. 71 004 918 825 A.C.N. 004 918 825  
 MELBOURNE AUSTRALIA

77 Taras Avenue  
 P.O. Box 363  
 Altona North  
 Vic 3025 Australia  
 Phone: +61(0)3 9369 1234  
 Fax: +61(0)3 9369 3456  
 Email: info@daviescraig.com.au  
 Web: www.daviescraig.com.au



## EWP<sup>®</sup> 115 ALLOY PUMP & EWP<sup>®</sup>-FAN DIGITAL CONTROLLER INSTALLATION INSTRUCTIONS

Congratulations on your purchase of the Davies, Craig EWP<sup>®</sup> 115 Alloy & EWP<sup>®</sup>-FAN Digital Controller which is designed to replace the existing belt driven mechanical water pump of your engine and to switch your Thermatic<sup>®</sup> Fan on and off. Your EWP has a very high flow capacity and has the advantage of running at a speed independent of the engine speed. The Digital Controller will vary the speed of your EWP in response to engine temperature and switch the Thermatic<sup>®</sup> Fan at 3°C above the set point. The EWP<sup>®</sup> will continue running after a hot engine shut down to prevent damaging heat soak. When your EWP<sup>®</sup> is used to replace the mechanical pump, you will notice an increase in engine power and torque, especially at high engine speeds. Automatic gear changes, both up and down, will be smoother.

***PLEASE READ THESE INSTRUCTIONS IN THEIR ENTIRETY BEFORE YOU START WORK***

**ALSO NOTE THAT THE EWP IS A 'CIRCULATION' PUMP IDEAL FOR 'CLOSED CIRCUIT' OPERATION SIMILAR TO AN AUTOMOTIVE COOLING SYSTEM. IT IS NOT A 'SELF-PRIMING' PUMP AND THEREFORE WILL NOT OPERATE WITHOUT A POSITIVE 'HEAD' IN AN 'OPEN' SYSTEM.**

### EWP<sup>®</sup> COMPONENTS:

| <u>No.</u> | <u>Description</u>           | <u>Qty.</u> |
|------------|------------------------------|-------------|
| 1.         | EWP Alloy pump               | 1           |
| 2.         | Inline adaptor               | 1           |
| 3.         | EWP & FAN Digital Controller | 1           |
| 4.         | Wiring Harness with 10A fuse | 1           |
| 5.         | Thin Rubber Sleeve           | 4           |
| 6.         | Hose Clamps                  | 4           |

### HARDWARE COMPONENTS:

| <u>No.</u> | <u>Description</u> | <u>Qty.</u> |
|------------|--------------------|-------------|
| 7.         | Hardware Bag       | 1           |
| ---        | Scotch lock        | 1           |
| ---        | Ring Terminal      | 2           |
| ---        | Self Tap Screws    | 5           |
| ---        | Temperature Sensor | 1           |



Figure 1: EWP115 Alloy and Digital Controller

---

## **SECTION ONE: INSTALLING THE EWP® 115**

1. The EWP® 115 Alloy is best fitted in the lower radiator hose connecting the radiator to the existing mechanical water pump housing and let the hose hold the weight of the pump and it will dampen from vibration too. Check the area for available space and shape of the hose. The section of radiator hose connected to the radiator must be connected to the inlet of the electric pump and the section of radiator hose connected to the original pump/engine block must be connected to the outlet of the electric water pump. The pump inlet is in the centre of the pump. The EWP® should be positioned as low as possible to maximise the gravity feed from the radiator and prevent air entering the pump. Alternatively, it can be fitted in the upper hose, but in this case the coolant level must be maintained and the section of the top radiator hose from engine block must be connected to the inlet of the electric pump and the section of radiator hose connected to the radiator must be connected to the outlet of the electric water pump. The pump can be installed in any orientation but to assist air bleeding try to mount the outlet pointing upwards.
2. Add 2 of the rubber sleeves if necessary (Item No 5) to the inlet and outlet, if required, to suit your particular hose diameter. If you need more thickness still, contact Davies, Craig and we will ship, free of charge same day sleeves to suit 2" (50mm) internal diameter hose.
3. Cut out the required section of the radiator hose. Connect the pump inlet and outlet to the appropriate hoses ensuring that the pump is oriented in the **BEST CORRECT ORIENTATION** as shown in Fig 7, page 9 "**BLEEDING THE EWP®**" during bleeding. Ensure hose clamps are tight.

**Do not bleed EWP® until you install the digital controller and disable the mechanical pump.**

### **Assmby of flanged adaptors ( Optional )**

The Davies Craig Alloy pump offers you an alternative option for mounting the pump. EWP115 Alloy pump is manufactured with 1"NPT internal thread at both the inlet and outlet. This enables you to conveniently screw in the various Davies, Craig flanged adaptors or use the appropriate dash fittings to suit your individual requirements or attach with hose using clips in the usual way.

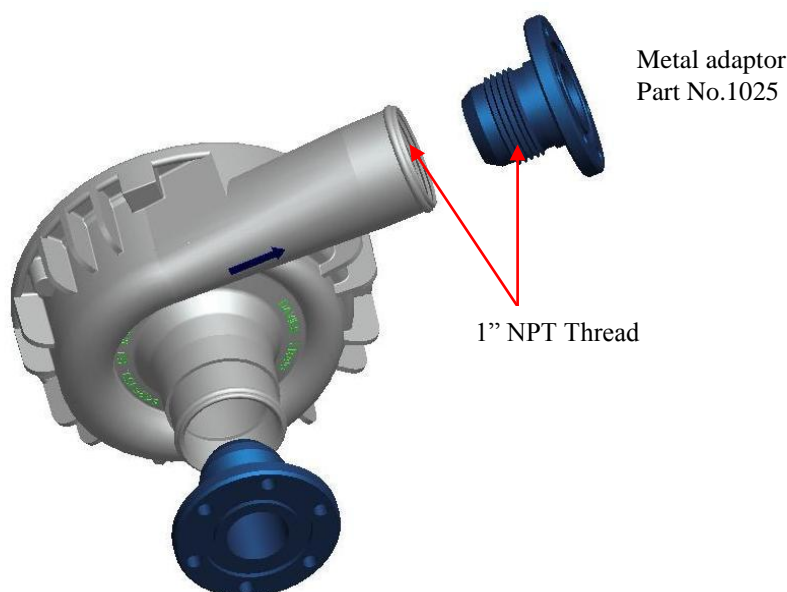

## **SECTION TWO:**

### **INSTALLING THE EWP<sup>®</sup> & FAN DIGITAL CONTROLLER (Refer Figure 2 below)**

**Do not begin the installation of the Digital Controller prior to the EWP<sup>®</sup> being installed.**

1. The controller must be fitted inside the passenger compartment. Locate a hole in the firewall (approx. 20mm in diameter) where the harness wiring (including the sensor & pump “T-connector”) will be able to pass through. If a spot of adequate size cannot be located, then wires may be cut then re-joined as a last resort.
2. Pass the “T-connector” of the wiring harness through the firewall into the engine bay and connect to pump.
3. Pass the **black** sensor connector through the firewall and out to the thermostat housing/ Inline adaptor (Refer page number 3 to 5 on installing digital controller sensor)
4. Connect the wiring harness to the controller and mount the controller (using 2 of the screws provided) in an appropriate position such as near the fuse box so that there is access to the temperature adjustment button --- **avoid mounting the controller where it may be exposed to direct sunlight**. Ensure a good earth connection using the self-tapping screw provided. NOTE: The earth lead must be connected to a metal part of the body.
5. An additional screw is provided for mounting controller fuse holder where necessary.
6. Connect the **red** wire from the wiring harness to the battery **positive** using the ring terminal provided. Connect the **green** wire from the wiring harness to an ignition source – the wires may be spliced then soldered if necessary. Ensure no wire is exposed, by insulating the join with electrical tape. Connect the **black stripped green** wire to the Fan relay if you wish to control the **Thermatic<sup>®</sup>** fan 3°C above the set point (refer to page 7, setting the Digital Controller)
7. Mount ‘Remote Test Light’ in a location, which will be visible. The ‘Test Light’ may be fitted by inserting it through a 4.6mm dia. drilled hole in a plastic area of the interior/dashboard or simply with adhesive tape. The ‘Remote Test Light’ has pin connections to assist installation. Heat shrink or insulation tape can be applied to these pin connections once the test light is mounted. This will ensure the connection points are insulated and secure.

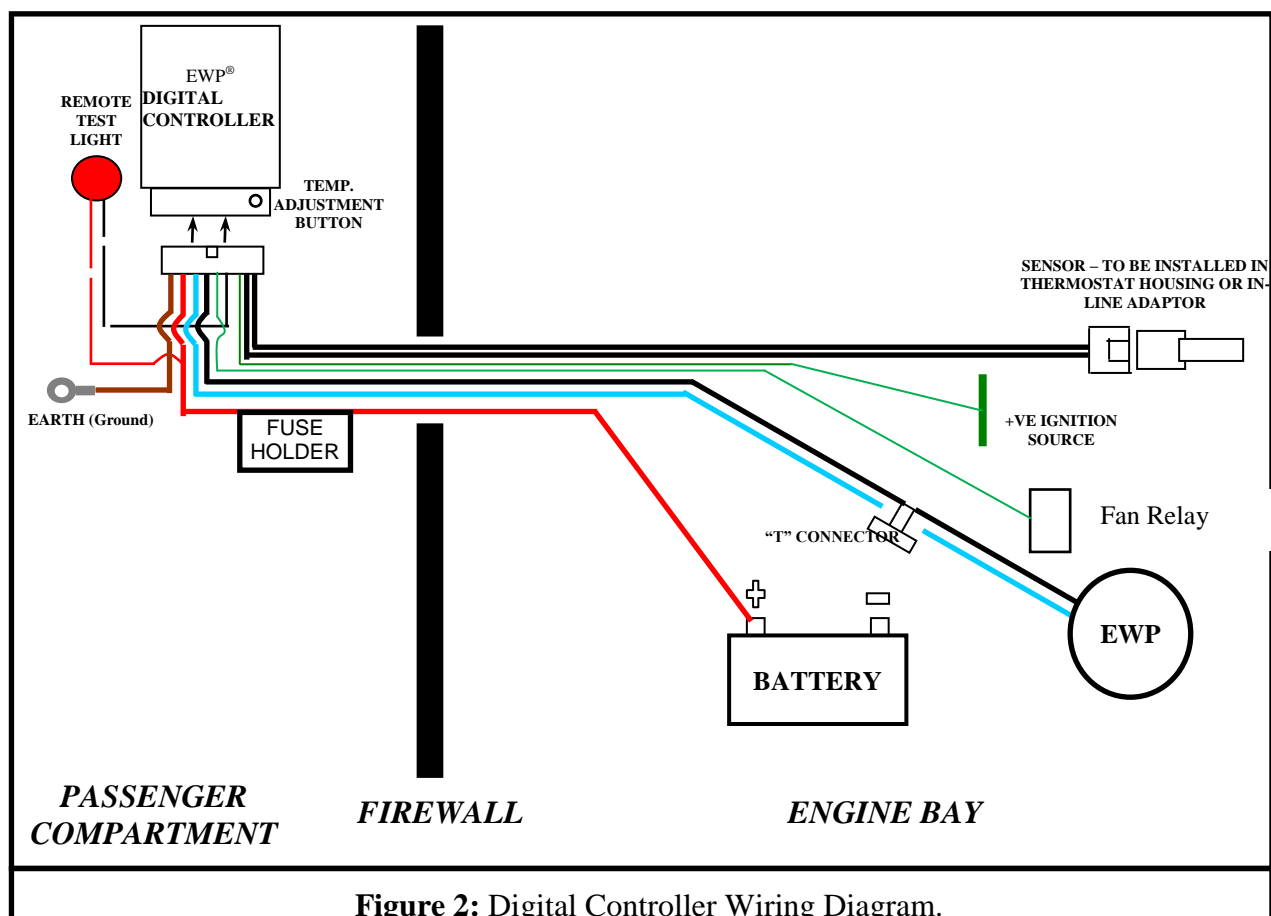

**Figure 2: Digital Controller Wiring Diagram.**

---

**NOTE:** In carrying out the wiring procedure, please bear in mind that it is advantageous to minimise voltage drop and this can be achieved by keeping the wiring as short as possible.

Remove the engine thermostat from the thermostat housing and install the sensor using method A or B as shown below. Re-fit the thermostat housing without the thermostat and ensuring that there is no damage to the thermostat-housing gasket.

### **DIGITAL CONTROLLER SENSOR INSTALLATION**

There are two installation methods available:

#### ***A) IN THERMOSTAT HOUSING METHOD***

*Please ensure these instructions are read in their entirety before proceeding with installation.*

- It is recommended that the Sensor assembly be installed in the thermostat housing (not supplied). However, please check wall thickness of thermostat housing as it is recommended that the Sensor assembly be installed only if there is a wall thickness of at least 3.0mm. If the thickness is less than 3mm, please proceed with installation method 'B'
- We suggest removal of the thermostat housing before beginning the installation process so that metal shavings do not enter the cooling system.

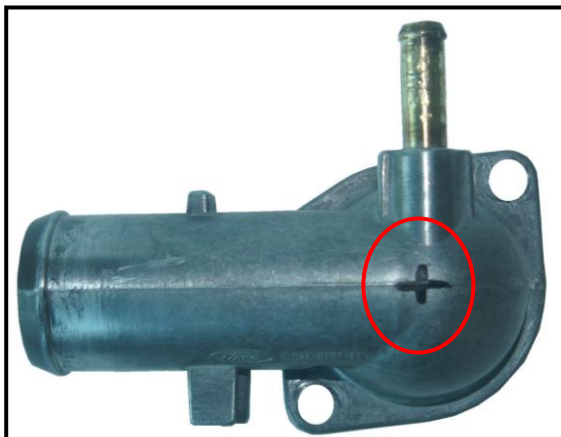

**STEP 1:** Mark location on thermostat housing where sensor assembly is to be fitted – “top of dome is recommended”.

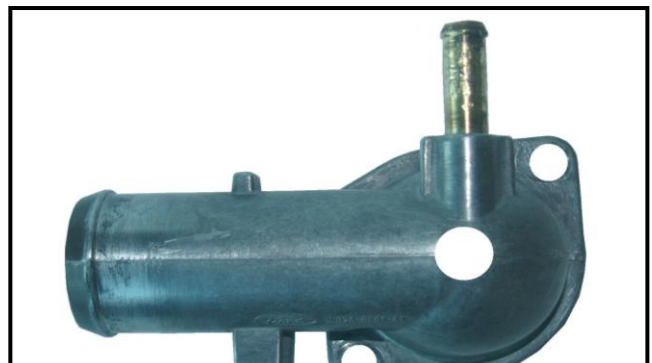

**STEP 2:** Drill an 11.0mm (7/16”) hole through the marked area. For your safety and to avoid drilling on an angle, please ensure thermostat housing is well secured before beginning the drilling process.

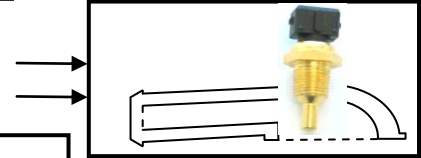
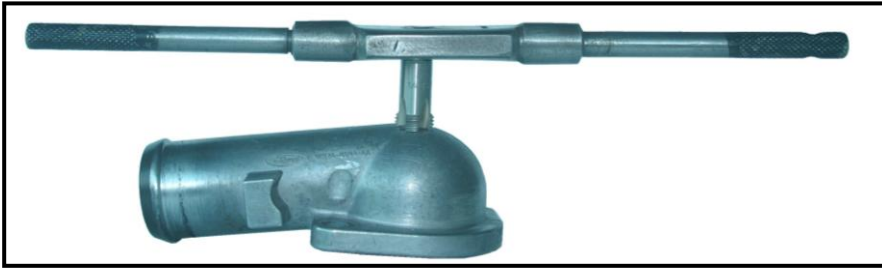

**STEP 3:** Using a ¼” BSPT tap, tap the hole to allow the sensor assembly to “just” protrude the thickness of the thermostat housing (refer to diagram). It is recommended that the fitment of the sensor assembly be checked regularly to achieve the condition in the diagram.

Figure3: Sensor Installation Method A

## ***B) IN-LINE ADAPTOR' METHOD***

As with other Davies, Craig products the ‘All-in-One’ adaptor has universal application.

### **Top Radiator Hose:**

**30 to 35 mm** inside diameter -- use adaptor without sleeves.

**36 to 42 mm** inside diameter – use 2 sleeves included in the kit (Item No.5)

**42+ mm** inside diameter – contact Davies, Craig

### **‘ALL-IN-ONE’ ADAPTOR INSTALLATION**

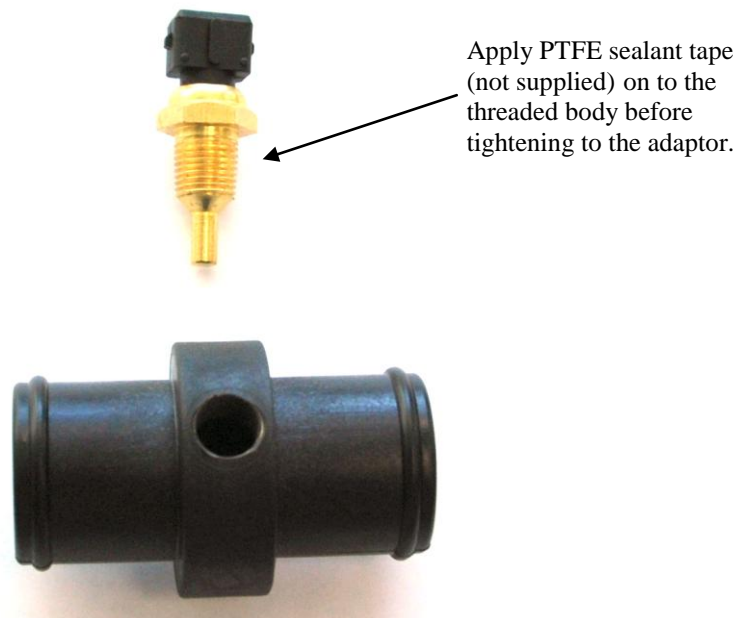

Figure 4: Sensor Installation Method B

## 1. Sensor Fitting

Apply a couple of layers of PTFE sealant tape around the threaded body of the sensor, Fit the sensor assembly in to the threaded black nylon adaptor and tighten.

**Do not over tighten, over tightening may damage the sensor body / adaptor.**

## 2. Hose Fitting

When the cooling system is cold, remove top radiator hose and confirm that the inside diameter of your top radiator hose is between 30 to 42 mm prior to cutting hose.

If the parts (adaptor and sleeves) provided in the kit are not suitable for your top radiator hose diameter please contact Davies, Craig before proceeding any further.

If the parts supplied (adaptor and/or sleeves) are suitable, cut your radiator hose to remove around 17 mm in length at an appropriate location. Select a location in a straight section of the hose.

Temporarily slide radiator hose clamps on each end of the hose. Fit both cut ends of hose onto adaptor (with or without sleeves as appropriate). If fitting is tight, use silicon base grease or petroleum jelly to assist fitment of adaptor to hoses.

Refit top radiator hose, ensure no twisting of hose and tighten all hose clamps.

# OPERATION

## CONTROLLER

### ALGORITHM-PUMP

#### OPERATION

Figure 5 shows the typical operational curve of the pump. The 'SET POINT' is the temperature at which full battery/system voltage is supplied to the pump. This can be set to any of the 5 'SET POINTS' available: 75°C, 80°C, 85°C, 90°C, 95°C.

## CONTROLLER

### OPERATION

#### LED CHECK:

Every time ignition is turned ON, all LED's will be on for 5 secs before returning to the normal operation mode. This feature allows for checking that all LED's are operational.

#### DIAGNOSTICS:

To avoid any premature diagnostic indication during 'temporary' events – especially where the engine is OFF for very short periods, the diagnostic functions will be activated 2 minutes after ignition is switched ON.

#### OVER-RUN MODE:

To reduce heat-soak after ignition shutdown, the controller will continue to run the EWP<sup>®</sup> for 2 minutes or until the temperature has reduced to 5°C below 'set-point' – whichever occurs first. The "Over-Run" feature will reduce heat soak but will be more effective when used in conjunction with a Thematic Fan.

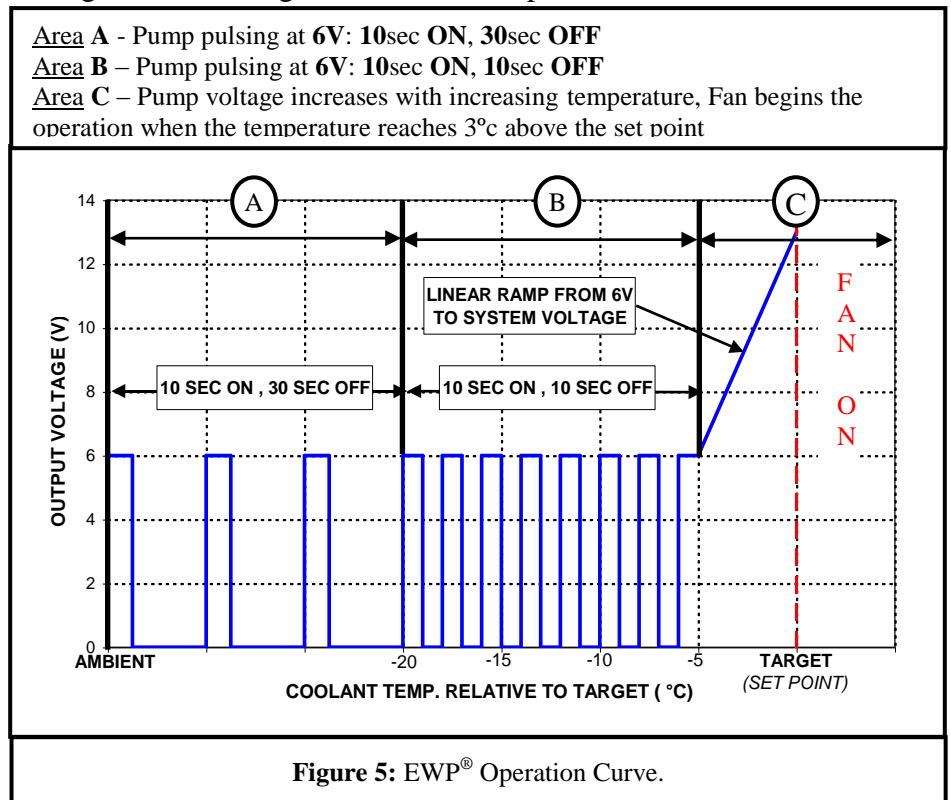

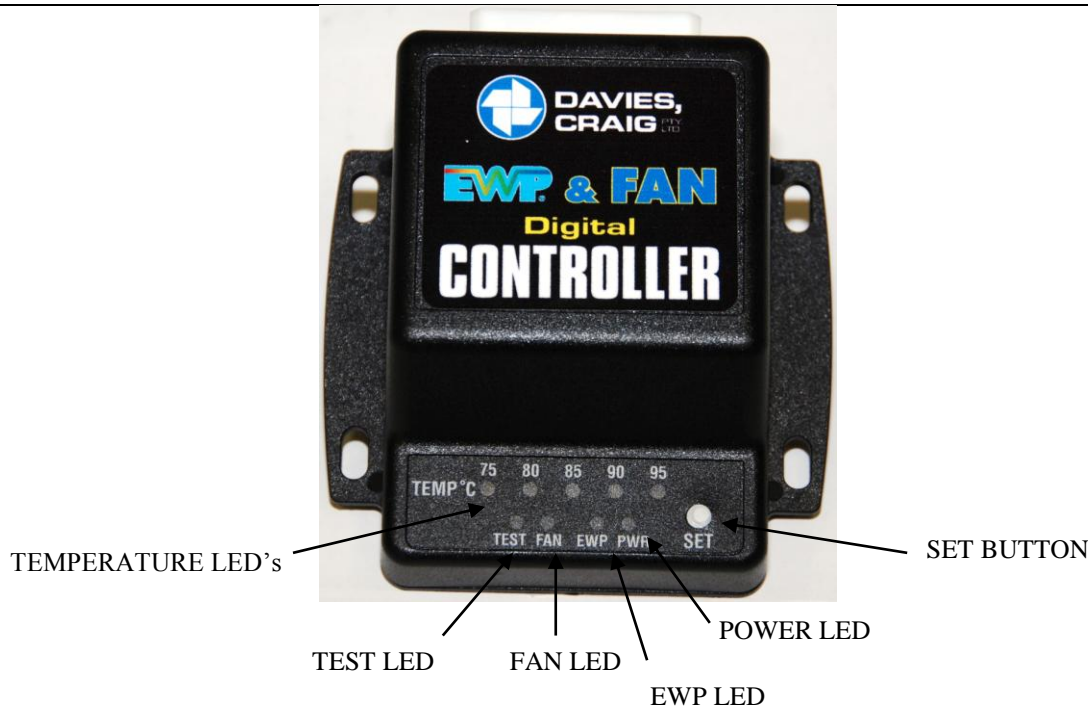

Figure 6: Controller Operation

**LED DISPLAY:**

The following identifies each LED and its operational status:

**TEMP LED (GREEN):**

*FLASHING 75°C LED*

*ON*

= Sensor temperature is below 75°C.

= ACTUAL sensor temperature.

**PWR LED (AMBER):**

*ON* = Controller has power.

**EWP LED (GREEN):**

*FLASHING* = EWP operating in ‘pulsing’ mode – Refer Figure 5, are (A) (B) .

*ON* = Electric Water Pump (EWP<sup>®</sup>) running between 6V – Battery Voltage: Refer Figure 5, area (C) .

**FAN LED (GREEN):** ON= Fan operating

**TEST LED (RED):**

*ON* = System warning has been triggered. Therefore, refer to “Diagnostic Chart” in order to determine possible cause, and take measures to correct the problem.

**REMOTE TEST LIGHT (RED):**

This light will “flash” whenever the TEST LED is on. The purpose of this light is to provide remote indication when the TEST LED has been activated.

**OVER-RUN MODE:**

During “Over-Run” mode:

- Actual sensor temperature will be indicated by GREEN temperature LED.
- PWR LED will flash
- EWP LED will be solid and pump will run at full battery voltage.
- FAN LED will be solid and Fan will run until temperature below the target temp.

## SETTING THE EWP® & FAN DIGITAL CONTROLLER

The Digital Controller can be set in accordance with your requirements. The factory 'set-point' on the controller is 85°C. This setting can be changed by using the 'set-point' adjustment button on the control panel as follows:

- i. Pushing the 'SET' button once will indicate the present setting with an amber LED.
- ii. When 'SET' button is held down, the 'set-point' settings will be scrolled through. Button should be released when desired 'set-point' is reached.
- iii. The LED will then flash and the setting must be confirmed ('locked in') by holding button down for 2 sec. If setting is not confirmed within 5 sec, controller will revert to previous setting.
- iv. To check 'SET' point, see (i) above.

It is recommended that initially the 'set-point' be set to approximately the mechanical thermostat opening temperature. Use a lower 'set-point' to run the engine colder or a higher 'set-point' to run the engine hotter. Generally, running the engine slightly colder will increase the power and running the engine slightly hotter will improve the fuel efficiency.

To verify 'SET' temperature, run the engine and monitor existing engine temperature gauge.

**NB: For your convenience, brief operating instructions are available on the reverse side of the controller.**

### Davies Craig Thematic Fan Wiring to the Digital Controller

**Please follow the below instructions 1&2 if you are using the wiring loom provided with Davies Craig Thematic Fan.**

1. Cut the green wire from the Fan wiring loom to a sufficient length, this wire (with relay) to be joined with the black traced green wire from the Digital Controller
2. Cut the black wire before the ring terminals attached, and then join sufficient length of wire to connect the battery positive as shown in the diagram below (85). Please discard the ring terminal part.

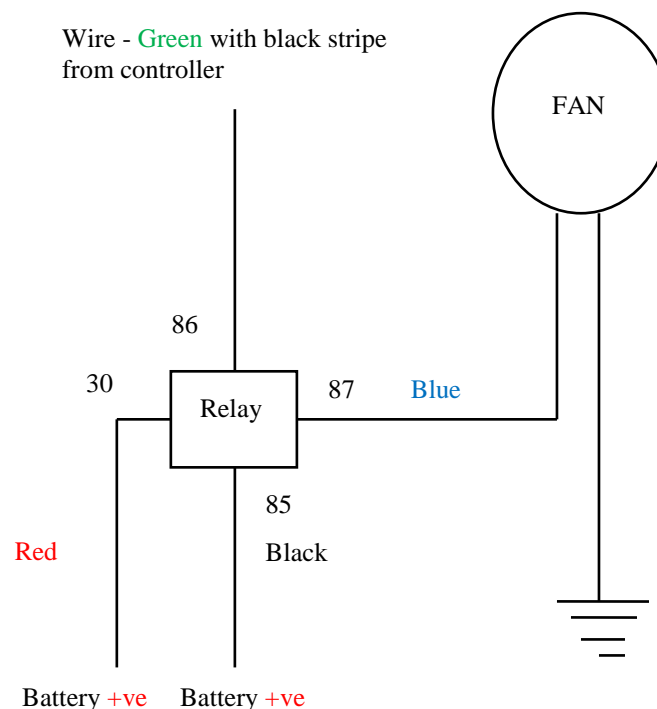

---

# EWP DIGITAL CONTROLLER

## Technical Specifications:

|                       |   |
|-----------------------|---|
| Input Voltage         | 12V DC to 13.5V DC  |
| Output Voltage        | 6V to 13.5V   |
| Max. Current          | 12A   |
| Operating Temperature | -20°C to 60°C (-5°F to 140°F)   |
| Setting Temperature   | 75°, 80°, 85°, 90°, 95°C<br>(167°, 176°, 185°, 194°, 203°F)           |
| Controller Type       | PCB with Micro Processor  |
| Sensor Type           | Thermistor in waterproof housing                                      |
| Time Out              | 2 Min. (or Set -5°C) after ignition OFF                               |
| Indicator LED's       | Temp., Power ON, Pump mode, Fan and<br>Test                           |
| Weight                | 90 grams (3.2 oz.)  |
| Dimensions            | 101mm (L) X 95mm (W) X 35mm (D)<br>[4" (L) X 3-3/4" (W) X 1-3/8" (D)] |

### MODIFYING EXISTING PUMP

To modify the existing pump, please do either:

1. Remove the existing belt driven water pump.
2. Pull the pump impeller off the belt driven pump shaft. (NOTE: You may need to drill holes through the impeller close to the drive shaft to make it easier to remove.) Be careful not to damage the seal or bearing when removing the impeller. Alternatively, remove vanes from impeller in situ.
3. Re-fit the belt driven water pump housing without the impeller ensuring that there is no damage to the water pump gasket and the pump seal is still retained. Re-fit the water pump belt and tighten to manufacturer's specifications.

**Or:**

By-pass the belt-drive on the water-pump, if possible, by installing a shorter belt that omits the pump pulley. This option is not possible if the pulley drives a belt-driven fan unless you replace the fan with a Davies, Craig Thermatic Fan<sup>®</sup>. For example:

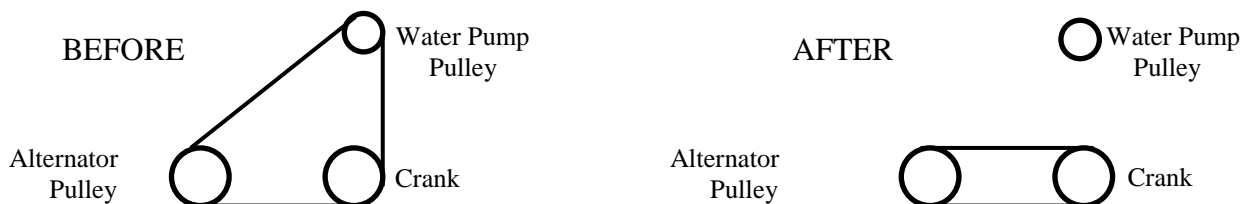

## **BLEEDING THE EWP®**

Ensure the EWP® is orientated correctly as shown below before continuing and hose clamps are tight.

NOTE: This orientation is a temporary requirement for the purpose of bleeding the pump and ensuring there is no air entrapped within the seal housing of the pump. The pump can be set-up in another orientation upon completion of the bleeding procedure.

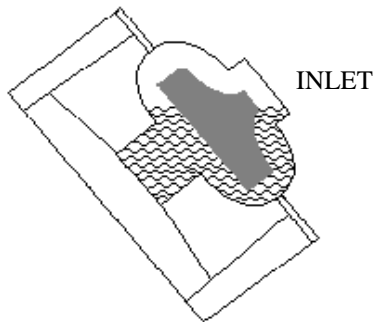

**FIGURE 7: BEST ORIENTATION**

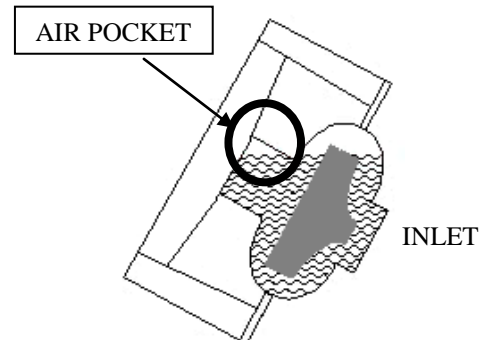

**FIGURE 8: INCORRECT ORIENTATION**

1. Fill up the cooling system with appropriate coolant.
2. Do not run the engine but temporarily hardwire the pump direct to the battery so that the pump runs at full power.
3. With the radiator cap off, run the pump for 5 - 10 minutes to ensure that there is no air trapped in the cooling system. Fill with coolant as the air is removed from the system.
4. Once all air is removed from the cooling system replace the radiator cap and reconnect the pump to your original controlling method.

**NOTE:** Slightly loosening the hose clamps and rotating pump to desired position can change the pump orientation. If leakage occurs from hoses during re-positioning, the coolant level must be topped up. Ensure that hose clamps are tight.

## **RUNNING THE EWP®**

Start engine to confirm no leakage at radiator hose or sensor and re-torque radiator hose clamps. Monitor the engine temperature, which should take slightly longer than usual to reach steady state.

Using EWP & Fan Digital Controller instructions digitally SET the temperature of the engine. It is recommended that initially the 'set point' be set to approximately the mechanical thermostat opening temperature. Generally, running the engine slightly colder will increase the power and running the engine slightly hotter will improve the fuel efficiency. The Digital Controller has an in-built function to run the EWP & Fan after ignition OFF and prevent engine heat soak.

Re-tighten hose clamps after a few hours operation at normal temperature and again after 20 hours running. Check for leaks. The cabin heater may take slightly longer than normal to warm up

**These installation instructions will suit most situations but there are conditions of engine design, environment, and the kind of motoring involved, which may call for other arrangements not described here. Advice is available from Davies, Craig and we would very much appreciate your feedback.**

If you encounter any difficulties during the installation and require further assistance, please contact Davies, Craig on +61 (0)3 9369-1234.

---

## **CAUTIONS**

- Use of the EWP<sup>®</sup> after removing the pump impeller or deleting the mechanical pump pulley from the belt system will increase maximum engine speed. Running an engine at higher speeds than normal may affect other engine components.
- Do not run pump dry as seal damage may occur and your warranty will be void.
- Engine temperature must be monitored closely at all times but especially immediately after installation and until pump operation and capacity have been proved.
- The EWP<sup>®</sup> can handle most rust particles and sludge found in cooling systems but large rust particles should be flushed from the radiator before the EWP<sup>®</sup> is installed.
- Some vehicles may require special bleeding procedures to remove air from the cooling system not described here. The EWP must be completely flooded with coolant at all times to achieve the life specification of the EWP and to preserve warranty.
- Do not use the vehicle's engine management system or wiring connected to the vehicle's engine management system as an ignition source because it may cause failure of the management system and/or the electrical system. The ignition source must be a steady positive supply of 12-14V DC.
- The cooling system should have antifreeze in accordance to the vehicle manufacturer's specification.
- The EWP is a 'circulation' pump ideal for 'closed circuit' operation found in an automotive cooling system. It is not a 'self-priming' pump and therefore will not operate well without a positive 'head' in an 'open' system
- The impeller tip clearance is very tight for maximum efficiency, and may when new actually scrape the pump housing causing a slight noise. The impeller will bed in over time and the noise cease.

## **EWP<sup>®</sup> Installation Recommendations**

To ensure maximum life and optimum performance from your new EWP<sup>®</sup>, Davies, Craig recommends:

- If an EWP<sup>®</sup> is installed on a vehicle which is kept in storage for more than 3 months, for example. a show or race-car, it is advised that the pump be operated for approximately 5mins constant running every month. This will minimise the build up of any sediment in the EWP<sup>®</sup> and also lubricate all parts within the pump.
- For improved heater performance on vehicles which have the heater inlet (return) and outlet ports in the mechanical pump housing (referred to in "Warnings"), Davies, Craig has developed the Electric Booster Pump, EBP<sup>®</sup>, part no 9001, which fits into the heater hose and boosts flow through the heater circuit and/or cylinder heads. There is more information on our web page [www.daviescraig.com.au](http://www.daviescraig.com.au)
- LPG (Liquid Petroleum Gas) vehicles require constant flow through the LPG converter and if the EWP<sup>®</sup> is used in conjunction with the Controller, we recommend the installation of an EBP<sup>®</sup> (Electric Booster Pump) to overcome freezing of the converter body at start up.
- It is recommended that the cooling system is flushed every 6 months or 10,000kms to remove any built up sediment in the cooling system.

## **⊕ WARRANTY**

We warrant that for a period of two years or 2000 hours continuous running (whichever is the lesser) from the date of purchase, we shall carry out, free of cost, any repairs that are reasonably necessary to correct any fault in the operation of your Electric Water Pump provided that such a fault is directly attributable to a defect in the workmanship or materials used in the manufacture of the part(s) and is not due to installation other than described in these instructions. Labour and consequential costs are excluded

**DAVIES, CRAIG PTY. LTD.**

11/06/2009

---

---

**WARRANTY REGISTRATION**  
*Part number 8030 – EWP115 Electric Water Pump  
& Digital Controller*

Name: \_\_\_\_\_

Address: \_\_\_\_\_

\_\_\_\_\_ Post Code: \_\_\_\_\_

Purchased From: \_\_\_\_\_ Date: \_\_\_\_\_

Fitted to vehicle: \_\_\_\_\_ Year: \_\_\_\_\_

Comments: \_\_\_\_\_

\_\_\_\_\_  
\_\_\_\_\_

Mail to: Davies,Craig Pty Ltd, P O Box 363, Altona North, Victoria, Australia 3025

**OR REGISTER ON-LINE AT [www.daviescraig.com.au](http://www.daviescraig.com.au)**

## COOLING SYSTEM DIAGNOSTIC CHART

The following table lists the Digital EWP® Controller diagnostic capability for your cooling system and the LED diagnosis sequence.  
**NOTE: In all instances where the TEST light is ON, the EWP is running at full battery voltage.**

|    | CONDITION  | LED SEQUENCE |       |       |            |            |            |            |            |       |       | TROUBLESHOOTING |   |
|----|--|--------------|-------|-------|------------|------------|------------|------------|------------|-------|-------|-----------------|---|
|    |  | TEST         | PWR   | EWP   | TEMP (75°) | TEMP (80°) | TEMP (85°) | TEMP (90°) | TEMP (95°) |       |       |                 |   |
| 1  | <b>Blown Fuse:</b><br>Controller does not operate.                                       | OFF          | OFF   | OFF   | OFF        | OFF        | OFF        | OFF        | OFF        | OFF   | OFF   | OFF             | Check fuse or connection.   |
| 2  | <b>Low Voltage:</b><br>Battery Voltage < 11V.  | ON           | FLASH | ON    | FLASH      | ON         | ON         | ON         | ON         | ON    | ON    | ON              | Check battery, alternator and/or regulator.                                 |
| 3  | <b>High Voltage:</b><br>Battery Voltage > 15.0V  | ON           | FLASH | ON    | ON         | ON         | ON         | ON         | ON         | ON    | ON    | ON              | Check battery or regulator.   |
| 4  | <b>Sensor Read Error 1:</b><br>Open-circuit on sensor lead or thermistor.                | ON           | ON    | ON    | FLASH      | OFF        | OFF        | OFF        | OFF        | OFF   | OFF   | OFF             | Check sensor wiring.  |
| 5  | <b>Sensor Read Error 2:</b><br>Short-circuit of sensor leads.                            | ON           | ON    | ON    | OFF        | OFF        | OFF        | OFF        | OFF        | OFF   | OFF   | FLASH           | Check sensor wiring.  |
| 6  | <b>Low Operating Temp Fault:</b><br>Sensor Temp < 30°C after two minutes.                | ON           | ON    | ON    | FLASH      | ON         | ON         | ON         | ON         | ON    | ON    | ON              | Check engine temperature.   |
| 7  | <b>Over-Temperature:</b><br>Sensor Temperature is at least 10°C above 'SET' point.       | ON           | ON    | ON    | ON         | ON         | ON         | ON         | ON         | ON    | ON    | FLASH           | Check sensor installation or cooling system. e.g. Fans, fan thermal switch. |
| 8  | <b>Set-Point Error:</b><br>'SET' point value stored is invalid.                          | ON           | OFF   | ON    | OFF        | OFF        | FLASH      | OFF        | OFF        | FLASH | OFF   | OFF             | Re-set; if this fails contact Davies, Craig.                                |
| 9  | <b>Pump Connection Error:</b><br>Open circuit on pump leads or pump leads not connected. | ON           | ON    | FLASH | FLASH      | FLASH      | FLASH      | FLASH      | FLASH      | FLASH | FLASH | FLASH           | Check pump wiring and operation.  |
| 10 | <b>Microprocessor Error:</b><br><i>Controller Programme Invalid.</i>                     | ON           | OFF   | OFF   | OFF        | OFF        | OFF        | OFF        | OFF        | OFF   | OFF   | OFF             | Contact Davies, Craig.  |

**NOTE:** When a temperature related error has occurred, this may not necessarily be associated with the pump but could be associated with the overall cooling system. e.g Fans, fan thermal switch, coolant level. Therefore, inspection should not be limited to the pump alone in trying to isolate the cause

**PLEASE RETAIN THESE INSTRUCTIONS FOR FUTURE REFERENCE**

---

This page left blank intentionally

# Booster Water Pump with Performance

## EBP ELECTRIC BOOSTER PUMP

2 YEAR WARRANTY



brushless motor  
magnetic drive  
- no shaft seal  
long life -  
heavy duty  
12 volt

EXCITING  
NEW  
PRODUCT

## High performance, compact and versatile 12v pump for a range of applications

The 12v Davies Craig Electric Booster Pump (EBP) with its high flow capacity and advanced design, makes it ideal for a range of applications including:

- Water to air intercooler cooling on high performance vehicles.
- As a booster for improving cabin comfort in cars, 4WD and recreational vehicles.
- Water cooled motor cycle engines as replacement of mechanical pump
- Water reticulation within boats, caravans, motor homes and for camping.
- Solar heating and irrigation
- Efficient cooling of go-karts
- For LPG vehicles where a constant flow of coolant is essential to ensure the LPG regulator does not freeze-up.

The range of applications is only limited by your imagination.

### Easy Installation

The EBP is compact and easy to install – just cut the appropriate hose and fit it directly.

For everything you need for DIY installation, the kit (part no. 9001) includes the pump, hoses, hose clamps, wiring, hose diameter adaptors and easy to follow installation instructions.

The pump and wiring is also available as a short kit (part no. 9002).

### Quality Construction

The EBP motor has no brushes to ever wear out and the pump is magnetically driven by the motor, which means that no shaft sealing is required. There is only one moving part, the impeller and it is floating in the coolant. The pump chamber is hermetically sealed for trouble free operation and the EBP is fully backed by a Davies Craig 2 year warranty.



INNOVATION - QUALITY - RANGE

CARS

OFF-ROAD

4 WDS

CARAVANS

GO-KARTS

MOTORCYCLES

BOATS

CAMPING

IRRIGATION

MOTORSPORTS

---

# Customised Chrome Fans



A Davies, Craig Customised Chrome Thermatic<sup>®</sup> Fan Kit is ideal for the open engine compartment street rods, show cars, custom cars and high performance vehicles. Limited Edition chrome fan kits have been produced for the enthusiast to save you all the necessary time and effort when choosing that bright, stylised, effective fan for your vehicle.

- All Customised Chrome Thermatic<sup>®</sup> Fan Kits are suitable for both condenser and radiator cooling.
- The Customised Chrome Thermatic<sup>®</sup> Fans provide; constant powerful air flow which increases air conditioning performance, cooler engine operation, low profile, high performance, increased engine power and lowers fuel consumption.
- All Davies, Craig Thermatic<sup>®</sup> Fans offer reversible polarity and blades for bi-directional, upstream (pusher) and/or downstream (puller) air flow as standard equipment.
- All Davies, Craig Customised Chrome Thermatic<sup>®</sup> Fan Kits are packaged complete with relay, wiring loom, mounting hardware and easy-to-follow fitting instructions for a quick and tidy installation.

## **Part # Description**

|       |        |     |
|-------|--------|-----|
| #0071 | DCSL10 | 10" |
| #0072 | DCSL12 | 12" |
| #0073 | DCSL14 | 14" |
| #0074 | DCSL16 | 16" |